

# Penelope 550

## BASIN SPECIFICATION



### Product Features

Product Code	2321 +Rail, 2321-R
Type of basin	Console
Material of basin	Mineral Cast
Capacity of basin	1 litre
Overflow Configuration	Overflow supplied Max tap flow rate 5 litres / minute
Colour options	White Gloss

- Can not be wall hung.
- The basin must be sealed to the top with an acetic cured silicone sealant.
- Epoxy type sealants must not be used.
- The basin is reversible.

Cabinet range (refer to applicable cabinet specifications)



INDICATES TOP SURFACE -----

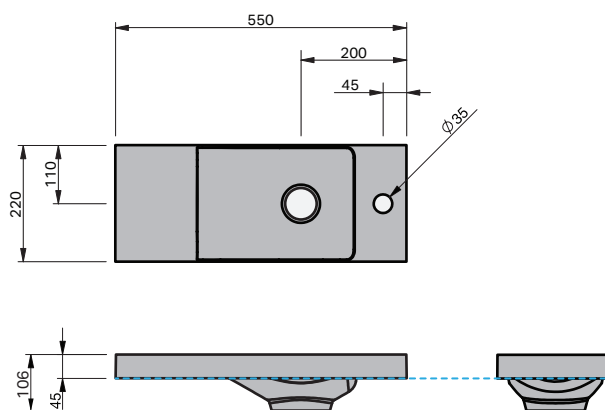

**IMPORTANT NOTE:** Throughout this guide, dimensions are nominal. Please read the installation manual for detailed information on installing the product. St. Michel pursues a policy of continuing improvement in design and manufacturing of its products. The right is therefore reserved to vary specifications without notice.

phone (09) 837 4276 email [info@stmichel.co.nz](mailto:info@stmichel.co.nz) [stmichel.co.nz](http://stmichel.co.nz)

st.michel  
BATHROOMWARE