

Cleo 600

BASIN SPECIFICATION



White Gloss
(with taphole)



White Matte
(without taphole)



Product Features

Product Code	White Gloss / 2704 White Matte / 2719-NT
Type of basin	Console
Material of basin	Mineral Cast
Capacity of basin	5.5 litre
Overflow Configuration	Integrated overflow Max tap flow rate of 9 ltrs / minute
Colour Options	White Gloss White Matte

- The basin must be sealed to the top with an acetic cured silicone sealant.
- Epoxy type sealants must not be used.
- **White Gloss version supplied with pre-drilled taphole.**
White Matte version supplied without tap hole. Drill kit supplied if taphole required.

INDICATES FURNITURE TOP SURFACE -----

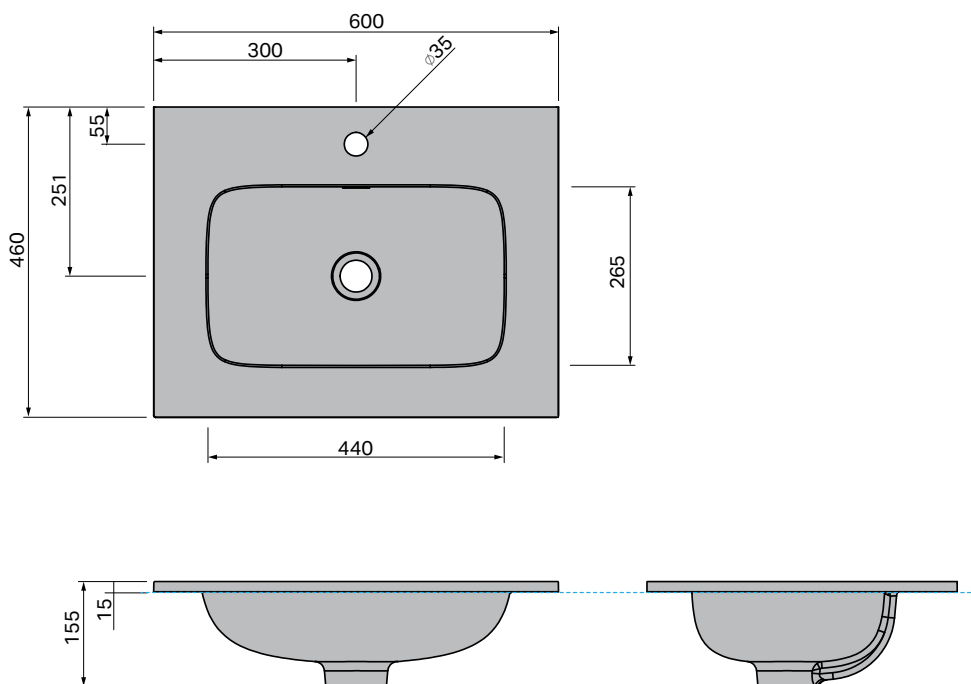

IMPORTANT NOTE: Throughout this guide, dimensions may vary by ± 2 mm. Please read the installation manual for detailed information on installing the product. St. Michel pursues a policy of continuing improvement in design and manufacturing of its products. The right is therefore reserved to vary specifications without notice.

st.michel
BATHROOM

phone (09) 837 4276 email sales@stmichel.co.nz stmichel.co.nz