

HARDWARE SPECIFICATIONS

HARDWARE: Moon shelf bracket



SPECIFICATIONS

Shelf Dimensions

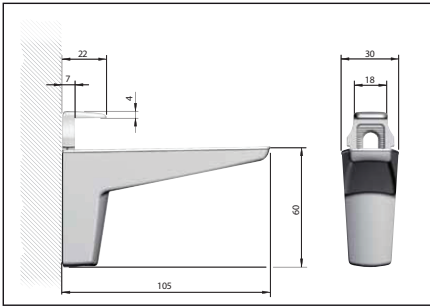

Position of the ridge plate for shelves 15-25mm

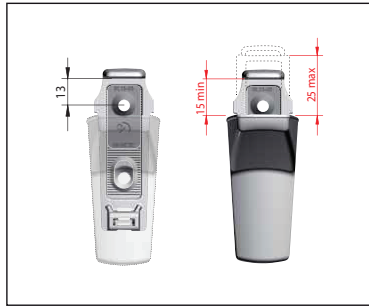

Capacity loading of the shelf

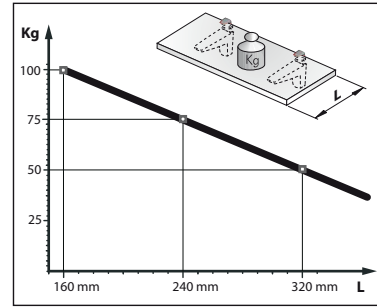

Verify the chart to determine the shelf capacity loading according to the shelf depth. The chart refers to a pair of shelf supports fixed to the wall with proper hardware fittings

INSTALLATION INSTRUCTIONS

1 **WARNING**
It is the responsibility of the customer:
- to ensure that the wall is of a suitable quality to hold the shelf fixing in place.
- to use the right hardware fittings as required.

2

3

4

1. Fixing the upper shelf support
Fix upper part using the blocking plate with a countersunk head screw Ø4 and a suitable wall plug.

2. Application of adhesive rubber insert
For glass shelves it's necessary to add the adhesive rubber insert on the upper part.

3. Bracket alignment
Align brackets vertically to obtain their perfect alignment.

4. Assembling of the lower shelf support
Tighten the M4 x 50 mm screw to lock the shelf.

St Michel pursues a policy of continuing improvement in design and manufacturing of its products. The right is therefore reserved to vary specifications without notice | Revised 06/2018