

AVOKA

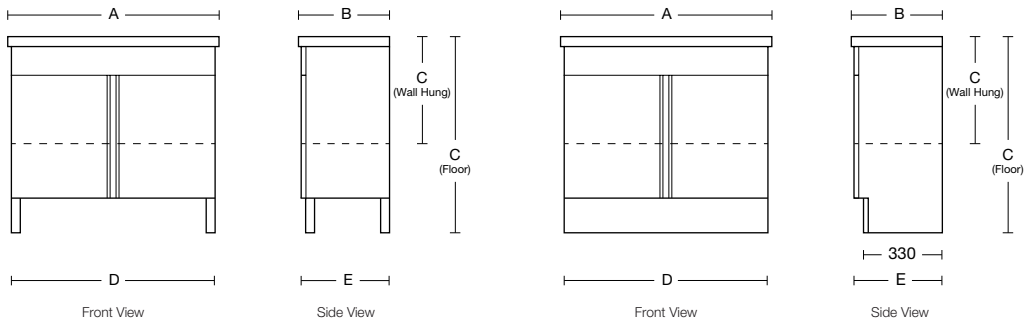

Avoka					
Description	A	B	C	D	E
Avoka Wall 500 2d	500	390	440	470	375
Avoka Floor 500 2d (Legs)	500	390	840	470	375
Avoka Floor 500 2d	500	390	840	470	375
Avoka Wall 600 2d	600	390	440	570	375
Avoka Floor 600 2d (Legs)	600	390	840	570	375
Avoka Floor 600 2d	600	390	840	570	375
Avoka Wall 700 2d	700	390	440	670	375
Avoka Floor 700 2d (Legs)	700	390	840	670	375
Avoka Floor 700 2d	700	390	840	670	375
Avoka Wall 800 2d	800	390	440	770	375
Avoka Floor 800 2d (Legs)	800	390	840	770	375
Avoka Floor 800 2d	800	390	840	770	375
Avoka Wall 900 2d	900	390	440	870	375
Avoka Floor 900 2d (Legs)	900	390	840	870	375
Avoka Floor 900 2d	900	390	840	870	375



All dimensions are in millimetres nominal. 06/12

AVOKA

- **Please note:** With wall hung vanities, we suggest you adjust the measurements to suit your individual height preference.

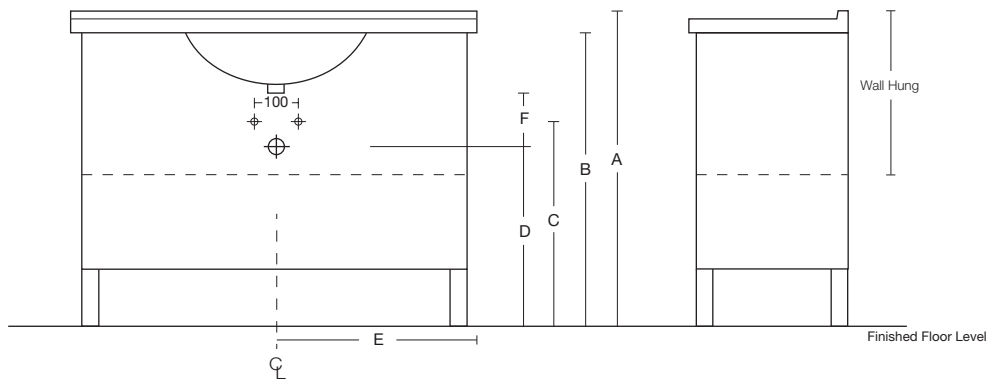

Description	Basin	A (Basin Top)	B (Cabinet Height)	C	D	E	F
Avoka 500	Clever	840	800	620	540	CL Basin	110
Avoka 600	Clever	840	800	620	540	CL Basin	110
Avoka 700	Clever	840	800	620	540	CL Basin	110
Avoka 800	Clever	840	800	620	540	CL Basin	110
Avoka 900	Clever	840	800	620	540	CL Basin	110

Standard Supply		<p>If you increase or decrease height of basin (i.e. dimension A) then C + D dimensions must be amended accordingly.</p> <p>F measurement is bottom of basin outlet to centre of wall waste pipe - if another waste trap is used, you will have to confirm F measurement suits or adjust accordingly.</p> <p>NOTE: Waste outlet positioned for standard chrome bottletrap and pop-up basin waste.</p>
Tap Hole	1	
Colour	White	
Integral Overflow	Yes	

All dimensions are in millimetres nominal. St Michel Industries Ltd has the right to change product and specifications without notice. 11/12