

BASIN SPECIFICATIONS

Product Name	Corinne 900 Single bowl
Product Description	Mineral Cast Vanity Basin
Nominal Size	900mm x 435mm

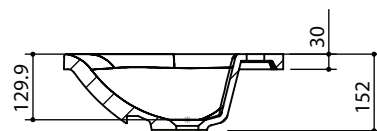
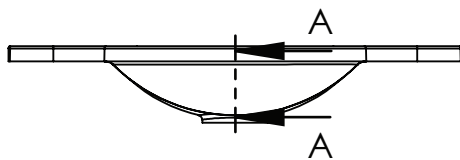
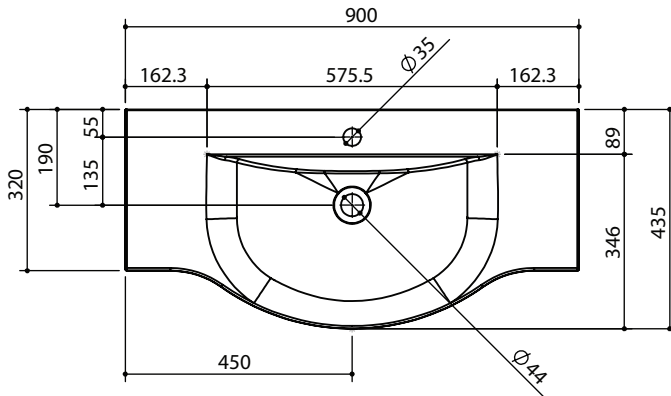

SECTION A-A

Bowl Water Volume:	9L
Overflow:	Overflow not provided.
Fixing:	The basin must be sealed to the top sections of the vanity unit with an acetic cured silicone sealant. Epoxy type sealants must not be used
Colour:	White Only
Dimensions:	All measurements are in millimetres and are +/- 2mm

St Michel pursues a policy of continuing improvement in design and manufacturing of its products. The right is therefore reserved to vary specifications without notice | Revised 01/2018