

# Palo 750

## BASIN SPECIFICATION



### Product Features

Product Code	5310
Type of basin	Console
Material of basin	Mineral Cast
Capacity of basin	6 litre
Overflow Configuration	Overflow supplied Max tap flow rate of 15 ltrs / minute
Colour options	White Gloss

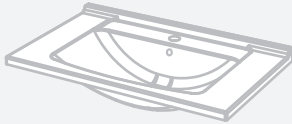

- The basin must be sealed to the top with an acetic cured silicone sealant.
- Epoxy type sealants must not be used.

INDICATES TOP SURFACE -----

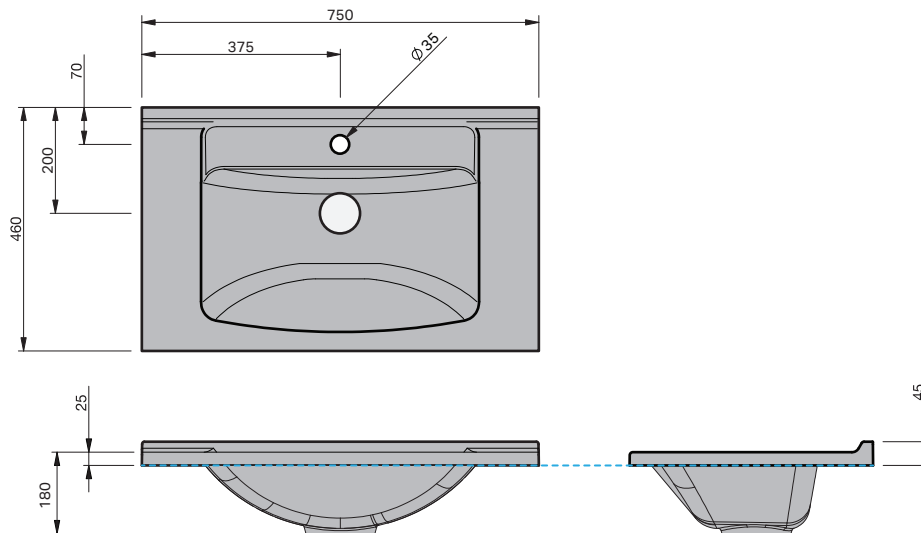

**IMPORTANT NOTE:** Throughout this guide, dimensions may vary by  $\pm 5$ mm. Please read the installation manual for detailed information on installing the product. St. Michel pursues a policy of continuing improvement in design and manufacturing of its products. The right is therefore reserved to vary specifications without notice.

**st.michel**  
BATHROOMWARE

phone (09) 837 4276 email [info@stmichel.co.nz](mailto:info@stmichel.co.nz) [stmichel.co.nz](http://stmichel.co.nz)