

Premo

BASIN SPECIFICATION



Product Features

Product Description	Premo Basin
Colour	White
Basin Material	Mineral Cast
Standard Tap Size	35mm
Standard Waste Size	32mm
Basin Depth	120mm
Overflow Configuration	Overflow supplied Max tap flow rate of 15 ltrs / minute

Premo							
Description	A	B	C	D	E	F	G
Premo	500	250	220	60	415	30	190
White Only - 1 Taphole							

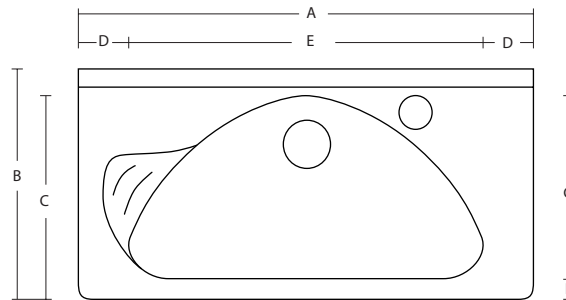

IMPORTANT NOTE: Throughout this guide, dimensions may vary by ± 2 mm. Please read the installation manual for detailed information on installing the product. St. Michel pursues a policy of continuing improvement in design and manufacturing of its products. The right is therefore reserved to vary specifications without notice.

st.michel
BATHROOMWARE

phone (09) 837 4276 email info@stmichel.co.nz stmichel.co.nz