

Spacer Kit Fixings & Instructions

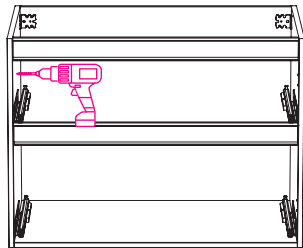

- 1** Pre-drill carcass side for spacer fixing 50mm from front of carcass. 3 holes per spacer recommended.

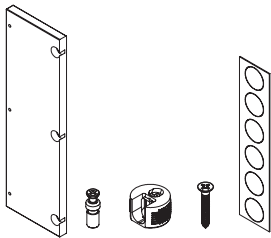
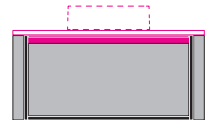

● ● Spacer

- 2** Choose your front facing spacer. Only applies when a blend is specified.

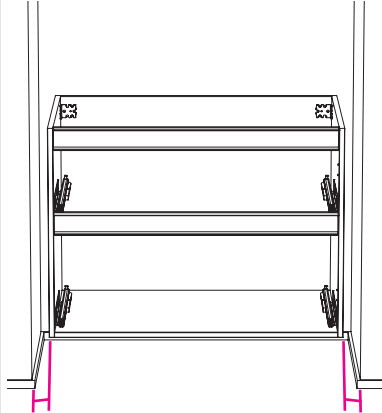

- 3** Measure gap to determine spacer width. 2 spacers = wall to wall. 1 Spacer = into corner.

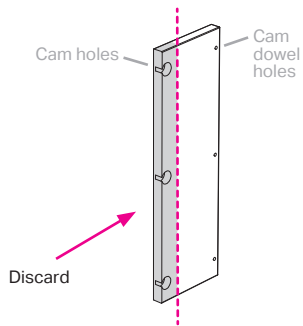

- 4** Trim your front facing spacer to fill gap. Cut away cam holes, leave cam dowel holes to connect to rear fixing panel. Note: Adjust trim angle to match any walls out of plumb.

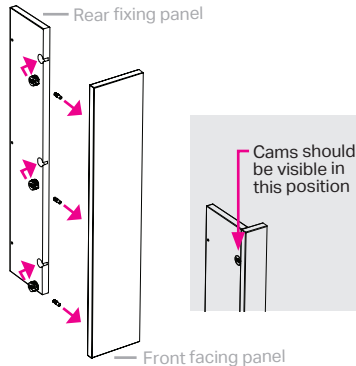

- 5** Screw cam dowels into trimmed outward facing panel. Knock cams into rear fixing panel + assemble.

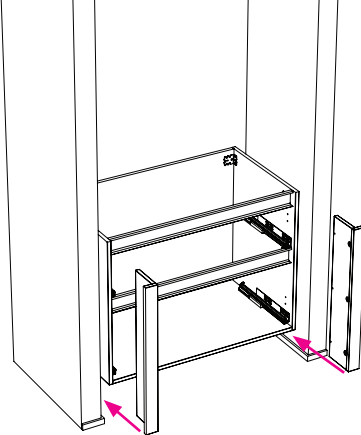

- 6** Fit spacers into gap.

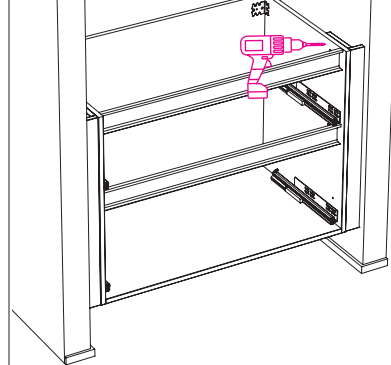

- 7** Secure your spacers - screws provided.
- 8** Put stick on cover caps over screw heads. Clean away all building residue & make sure drawer runners have had debris removed.